

Component design to go into schedule 40 SPEARS or NIBCO Tee and Caps

For HyZor and ER50 electrolyzer designs using Gas Relief tubes.

Copyright © 2013-2017 Eagle-Research, Inc

www.eagle-research.com George Wiseman, george@eagle-research.com 905-329-3858

Specifications for all three 'plate' designs

24 gauge (or least expensive gauge) of 316L Stainless Steel

Plate edges should be smooth, but a little pull, or dross is OK

Plate corners slightly rounded where meet flat edge; NO sharp points.

Neutral Zone Plate

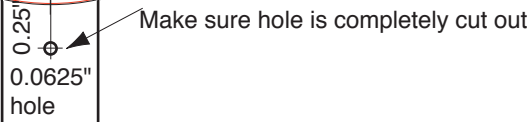
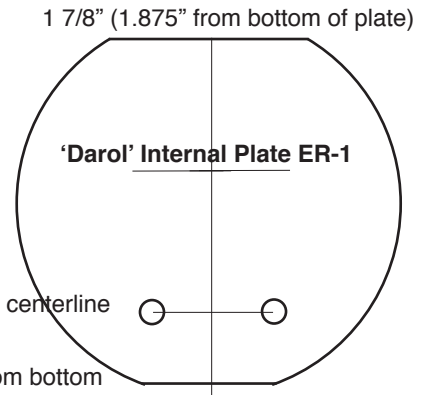
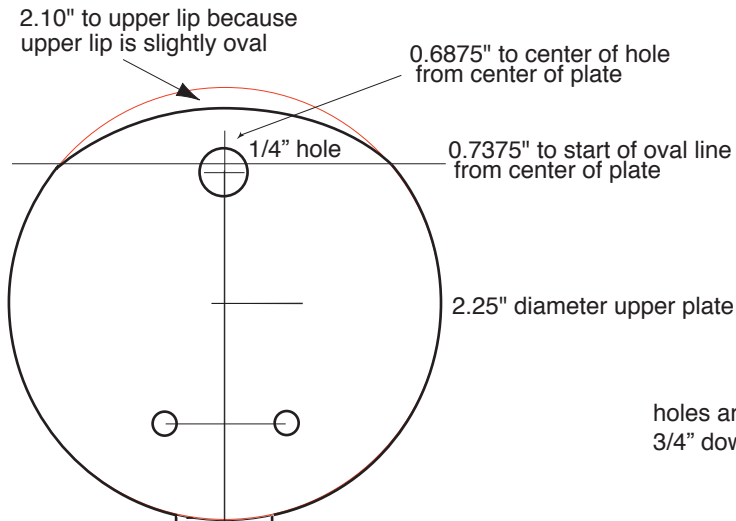

Connecting Strip
0.50" wide
2.4375" long

holes are 1/8" diameter, 3/8" from centerline 3/4" down from center of circle

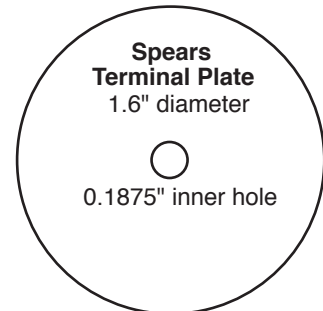

2 slots 0.125" long, narrow as possible

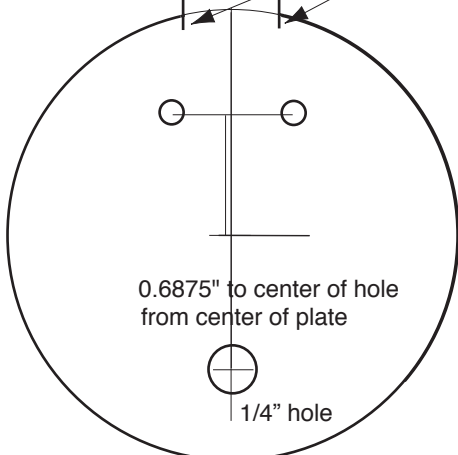

2 11/32 = 2.344" diameter lower plate